



Integrated Systems Engineering & Products

PROTOCOL CONVERTER
MODBUS RTU TO YORK TALK

User Manual

DOCUMENTED BY

ISEP

Updated: 26 June 2003

Table of Content

1	INTRODUCTION	2
2	SYSTEM CONFIGURATION	2
3	CONVERTER DESCRIPTION	3
4	OVERVIEW OF COMMUNICATION PROCESS	4
5	DATA ARRAY MAPS	5
6	PCB MOUNTING DIMENSION	7
7	OPTIONAL ENCLOSURE BOX	7

1 Introduction

The MODBUS RTU to YORK TALK Protocol Converter facilitates data communications between a MODBUS RTU master and one York Talk XL Translator that can be connected to a number of Chillers. It does this by converting MODBUS RTU queries to equivalent York Talk commands. The York Talk commands are transmitted on a three-wire RS-232 cable, and only the Chiller with address that matches respond. Upon receipt of the York Talk response, the converter will translate it to MODBUS RTU recognizable by the MODBUS RTU master device.

2 System Configuration

In the monitoring system, one or more Chiller could be monitored. A PLC or PC can be the MODBUS RTU master. The Chillers are the slave devices. The converter is connected to MODBUS RTU master as a slave via the RS232 port with a RS232 to RS485 converter converting to RS485. The converter is connected to York Talk XL Translator as a master via the RS232 port. The system configuration is shown below.

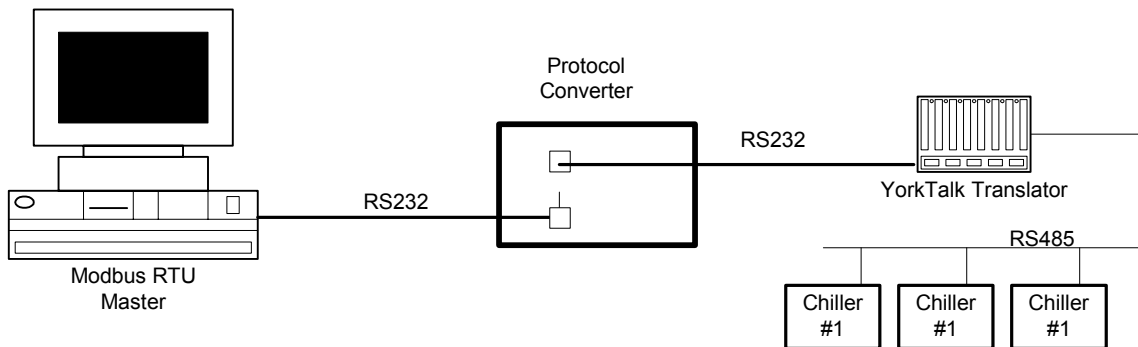

3 Converter Description

The converter PCB is designed to slot into a holder.

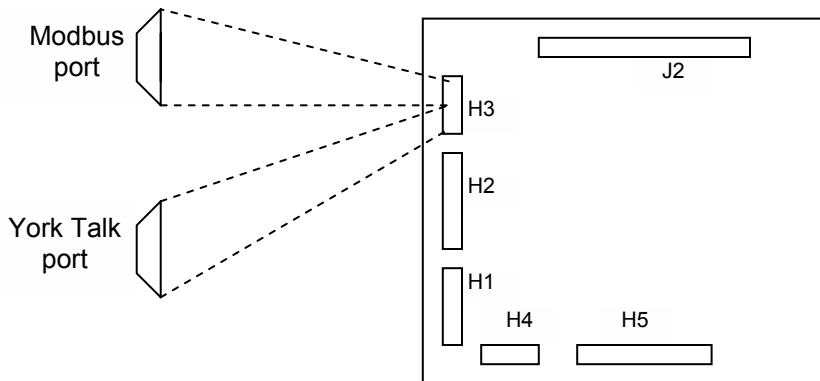

The pin description for the 9 pin D connector is shown below.

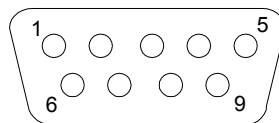
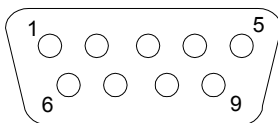

9 Pin Male Connector (York Talk Port)	
Pin #	Description
2	Tx
3	Rx
5	Ground
rest	No connection

9 Pin Male Connector (MODBUS Port)	
Pin #	Description
2	Rx
3	Tx
5	Ground
rest	No connection

The pin description for H3 on the PCB is shown below.

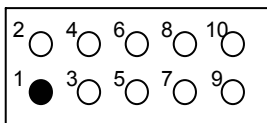

H3 Connector (BL 1600)	
Pin #	Description
3	Tx0
4	Rx1
5	Rx0
6	Tx1
9	Ground
rest	No connection

4 Overview of Communication Process

This section provides an overview of the communication processes that takes place within the York Talk Translator, the MODBUS RTU master and the protocol converter.

The protocol converter begins a series of events upon receiving a valid MODBUS RTU query from the MODBUS RTU master. Currently, the valid query is Read Registers. The converter will ignore any queries other than those stated above.

On power up, the converter monitors the MODBUS RTU port continuously for queries. While the York Talk port will keep polling and receiving data, and store in the common memory. The converter will only respond to queries with the function codes 3 which correspond to the query mentioned above.

Upon receipt of a valid query, the converter will get the data from the common memory and sent through MODBUS RTU response. This is less than 500 milliseconds, that is the maximum amount of time that a MODBUS RTU master can wait for the response from the converter after a query have been sent. If no response is received from the converter, the converter will abort the communication process of the current query and wait for a new MODBUS RTU query. The whole communication process of the current query could be finished before the MODBUS RTU master send next query.

For only the Modbus RTU communication ports of the converter, the converter will do the error check first after a packet is received. The CRC-16 code of the MODBUS RTU is used for error check. If a message from Modbus RTU with errors in its CRC, the converter will ignore this message and wait for next message. The converter will not response to the MODBUS RTU master if that particular chiller had not been communicating with the York Talk Translator. If a query with errors is received, the converter will ignore this query and wait for next query.

5 Data Array Maps

The data are 16-bit integer.

Field	Address	Bit	Field	Address	Bit
P01 LCHW_TEMP.SP	40001	0-16	P32	40055	0-16
	40002	0-16		40056	0-16
P02 %CURRENT.SP	40003	0-16	P33	40057	0-16
	40004	0-16		40058	0-16
P03	40005	0-16	P54 AR_TIME.MIN	40059	0-16
	40006	0-16		40060	0-16
P04	40007	0-16	P55 OPR_MOD.CODE	40061	0-16
	40008	0-16		40062	0-16
P09 LCHW.TEMP	40009	0-16	P56	40063	0-16
	40010	0-16		40064	0-16
P10 ECHW.TEMP	40011	0-16	P57 SAFETY.CODE	40065	0-16
	40012	0-16		40066	0-16
P11 EVAP.PRESS	40013	0-16	P58 CYCLING.CODE	40067	0-16
	40014	0-16		40068	0-16
P12 COND.PRESS	40015	0-16	P59 TM_INT.TEMP	40069	0-16
	40016	0-16		40070	0-16
P13 OIL.DP	40017	0-16	P60 TM_CHSKTEMP	40071	0-16
	40018	0-16		40072	0-16
P14 ECDW.TEMP	40019	0-16	P61 ACC_PRV_POS	40073	0-16
	40020	0-16		40074	0-16
P15 LCDW.TEMP	40021	0-16	P62 ACC_FRZ.HZ	40075	0-16
	40022	0-16		40076	0-16
P16 %CURRENT	40023	0-16	P63	40077	0-16
	40024	0-16		40078	0-16
P17 PHASE_A.AMPS	40025	0-16	P64	40079	0-16
	40026	0-16		40080	0-16
P18 PHASE_B.AMPS	40027	0-16	P65	40081	0-16
	40028	0-16		40082	0-16
P19 PHASE_C.AMPS	40029	0-16	P66	40083	0-16
	40030	0-16		40084	0-16
P20 A-B.VOLTS	40031	0-16	P67 ACC_DLTA_P/P	40085	0-16
	40032	0-16		40086	0-16
P21 B-C.VOLTS	40033	0-16	P68 TM_O/P.VOLTS	40087	0-16
	40034	0-16		40088	0-16
P22 C-A.VOLTS	40035	0-16	P69 TM_I/P.KW	40089	0-16
	40036	0-16		40090	0-16
P23 LCHW_ACT.SP	40037	0-16	P70 TM_I/P.HWAR	40091	0-16
	40038	0-16		40092	0-16
P24 %CURR_ACT.SP	40039	0-16	P71 TM_DCLK.VLT	40093	0-16
	40040	0-16		40094	0-16
P25 EVAPSAT.TEMP	40041	0-16	P72 TM_DCLK.CUR	40095	0-16
	40042	0-16		40096	0-16
P26 CONDSAT.TEMP	40043	0-16	P73 TM_SRG_CONT	40097	0-16
	40044	0-16		40098	0-16
P27 DISCH.TEMP	40045	0-16	P74 TM_O/P.HZ	40099	0-16
	40046	0-16		40100	0-16
P28 OIL.TEMP	40047	0-16	P75 TM_AVGV.THd	40101	0-16
	40048	0-16		40102	0-16
P29 PURGE.PRESS	40049	0-16	P76 TM_AVGI.TDD	40103	0-16
	40050	0-16		40104	0-16
P30 RUN.HOURS	40051	0-16	P77 TM_I/O.KVA	40105	0-16
	40052	0-16		40106	0-16
P31	40053	0-16			
	40054	0-16			

Field		Address	Bit	Field		Address	Bit
P05	START	40107	0	P46	ACC_VAILD_MAP	40108	0
P06	HISTORY	40107	1	P47	ACC_SURGE	40108	1
P07	TM_FIX/VR_SP	40107	2	P48	TM_CLGMP	40108	2
P08		40107	3	P49	TM_FLT519	40108	3
P34	COMPR.STAT	40107	4	P50	SURGE_TYPE	40108	4
P35	VENTSOL.STAT	40107	5	P51		40108	5
P36	CHWPUMP.STAT	40107	6	P52		40108	6
P37	STARTSW.STAT	40107	7	P53		40108	7
P38	CHWFLSW.STAT	40107	8	P78		40108	8
P39		40107	9	P79		40108	9
P40		40107	10	P80		40108	10
P41		40107	11	P81		40108	11
P42		40107	12	P82		40108	12
P43		40107	13				
P44		40107	14				
P45		40107	15				

6 PCB Mounting Dimension

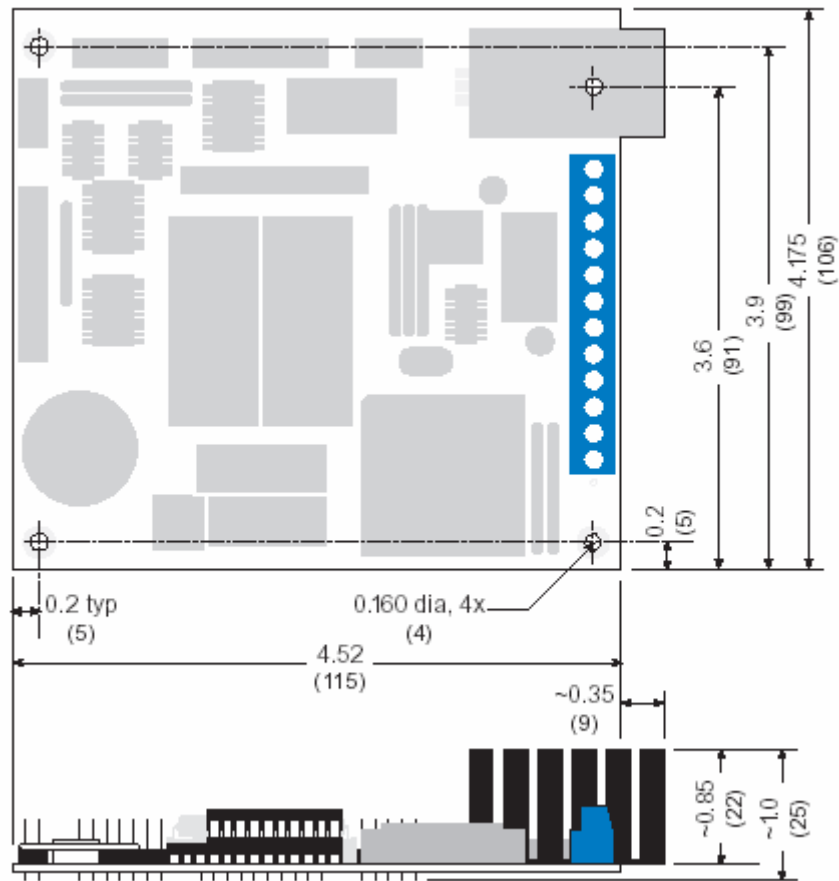

PCB Mounting Dimension

7 Optional Enclosure Box

Height: 64 mm
 Width: 154 mm
 Depth: 159 mm